

LET'S PLAY IT SAFE

PREVENTIVE EXPLOSION PROTECTION AND AUTOMATION

MONITOR
CONTROL
PROTECT



robecco

- secure center[®] (RSC)
- G.A.S.[®]
- inert control (RIC)
- dust control (RDC)
- silo automation (RSA)



Scan QR-Code
to learn more

RISK



DUST EXPLOSION HAZARDS

exist in

- Mills
- Spray Dryers
- Dryers
- Filters – Dust Collectors
- Silos
- Conveyers
- Separators
- Dedusting Screens
- Mixers

IGNIATION SOURCES

are

- Smouldering Nests
- Hot Surfaces
- Mechanically-Induced Sparks
- Sparking Electrical Equipment
- Flames
- Electrostatic Discharges

PRODUCTS

are

- combustible dust in powder-air mixtures

PREVENTIVE EXPLOSION PROTECTION CO / O₂ MONITORING AND CONTROL

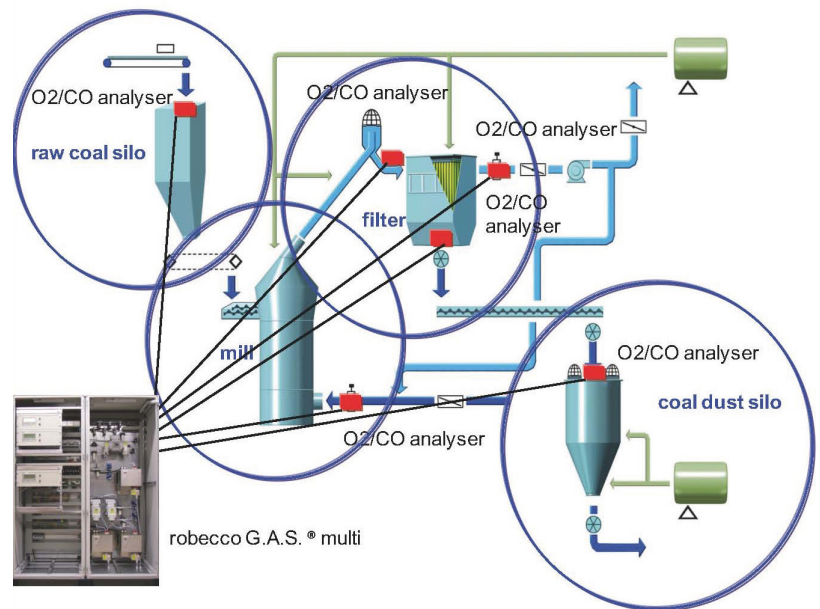

Fire and Explosion Risks:

- Fires and Explosions generate high risks for people, the environment and production installations. The consequences are significant developments of heat and pressure.
- The fire and explosion safety of an installation is determined by risk factors of the process and products.
- High temperatures and material product characteristics can develop dangerous smouldering fires in the production process.
- A proven technology is the use of Carbon Monoxide (CO) analysis for early fire detection and Oxygen (O₂) analysis to control the inert atmosphere. This is recommended according to CEN/TR 15221 and VDI guideline 2263/2.
- Early detection of smouldering fires allows the operators to mitigate fire propagation with help of technical measures. Continuous Carbon Monoxide (CO) and Oxygen (O₂) monitoring is essential to ensure prevention against fires and explosions.

robecco secure center is a central fully automatic control system, which guarantees the inert atmosphere during chemical and physical processes. Sensors and actors are connected by the system which prevents effectively dangerous process situations. robecco secure center controls and regulates at the community level or also separately the following components:

- A: Gas Analyser Systems**
- B: Temperature Sensors**
- C: Inerting Systems**
- D: Valves and Flaps**

General:

- Full automatic monitoring and control system
- Visualisation of the complete safety and inerting process
- Fully adaptable at operator CCR
- User friendly operation
- Service and Maintenance Monitoring
- Remote maintenance available
- Failure indication in clear text messages
- Trend view and data memory
- Design according to GEN/TR 15281 and VDI 2263/2
- Full Services (Project engineering, Manufacture, Commissioning and Training)

Technical characteristics:

- Connectable at higher control levels
- Self sufficient system functions without upper PLC control
- Exact CO₂- or N₂- dosing regarding effectiveness and environment
- Controlling of CO₂- or N₂- storage to guarantee the procurement and stock
- Monitoring of system relevant functionalities of the inerting system, gas analyser systems and temperature sensors
- Automatic determination of maintenance intervals of single components in dependence of operation duration
- Cabinet dimensions: 800 x 2100 x 600mm (W x H x D), or also possible to be integrated into the gas analyser cabinets
- Protection Class: IP55
- Installation site: closed rooms without ATEX- Zone
- Ambient operating temperature: -10 ... + 40°C
- Power supply: 110V AC; 230V AC/ 50 – 60Hz
- Interfaces: Profibus DP, Profinet, Ethernet

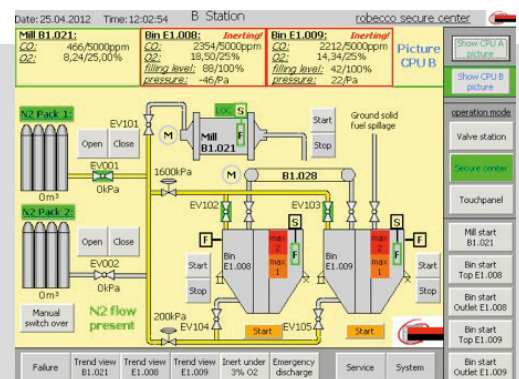
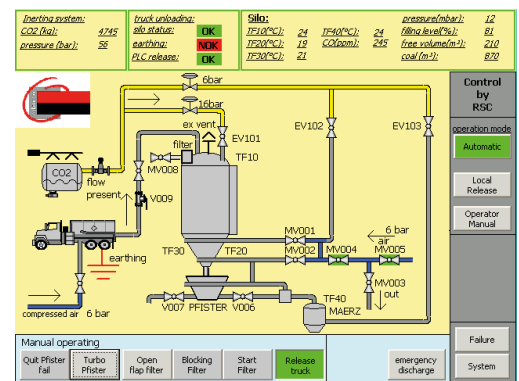
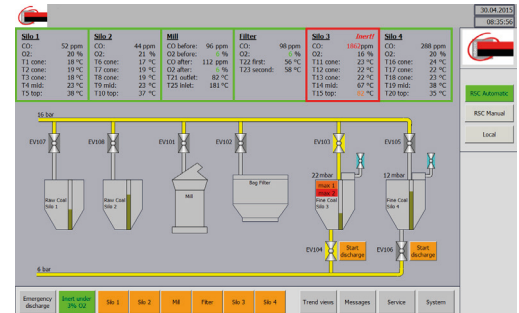

Application:

- Coal grinding systems
- Process Filter
- Storage Silos
- Dryers
- Gas Dosing Applications
- Other applications on request

robecco reliably undertakes the measurement of safety-related parameters during the operation of explosive processes. Oxygen, CO and CH₄ measurements are indispensable for operating inert gas units. The use of safety-related parameters is essential for applying preventive explosion control. Taking action requires information on the limiting concentration of Oxygen and the CO/CH₄ concentration of air-dust mixtures. Measuring and control systems have to fulfil certain requirements (ATEX Directive).

General:

- Measurement systems, monitoring and control units for different gases (gas measurement list on request) and processes
- Measurement of process safety related parameters
- Emission measurement systems
- Gas warning units for stationary gas storages, air monitoring, workplace security
- Oxygen Sensors
- Extractive gas sample systems with sample probes and sample lines
- Flexible sample lines (Lengths, power, heated and non heated version)
- ATEX certified equipment for explosive areas
- Full Services (Project engineering, Manufacture, Commissioning and Training)



Technical Dates:

- System dimensions: 800-2400 x 2100 x 600mm (W x H x D)
- Protection class: IP55, IP65 on request
- Operating temperature: 0... +35°C
- Sample probes: with pre-filter, electrically heated, filter cleaning unit
- Sampling temperature: max. +200... +600°C (on request more)
- Process pressure at sample probe: 0,5... 6bar
- Sample line: including self-regulated heater and compressed air filter cleaning unit
- Ambient temperature at sample line: -20... +60°C
- Lengths of sample line: free confection until 100m
- ATEX and non ATEX execution
- Operating modes: continuous or selective
- Power supply: 110V AC; 230V AC; 50 – 60Hz
- Interfaces: Profibus DP, Profinet, Ethernet, Potential Free Contacts

Application:

- Coal grinding systems
- Process Filter
- Storage Silos
- Dryers
- Kilns
- Other applications on request

robecco inert control RIC is an automated control system for inerting systems which are operated with CO₂ or N₂. To reduce limiting oxygen concentrations (LOC) for preventive explosion protection under critical limits it is necessary to purge inert gases like CO₂ or N₂ into the explosive process atmospheres. robecco inert control offers a complete and flexible solution for inerting systems.

General:

- Touch panel visualisation and operation
- System relevant parameter indications
- Local control and remote control mode
- Failure indication
- Reliable performance
- Integrable in the full automatic control system robecco secure center
- Full Services (Project engineering, Manufacture, Commissioning and Training)

Technical Dates:

- System dimensions: 800 x (1000-2000) x 400mm (W x H x D);
- Protection class: IP55, IP65
- Ambient temperature: -10... +40°C
- Power supply: 110V AC; 230V AC; 380 – 460V AC/ 50 – 60Hz
- CPU Controller
- Monitoring and Operator Display
- Interfaces: Profibus DP, Ethernet, Potential free contacts

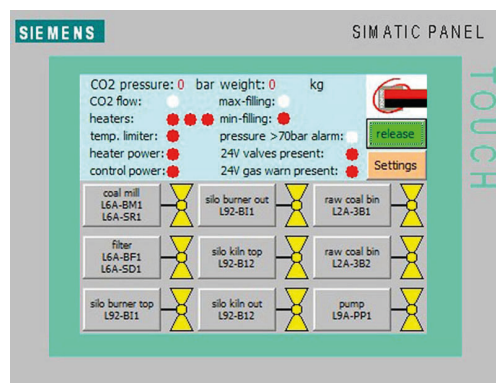
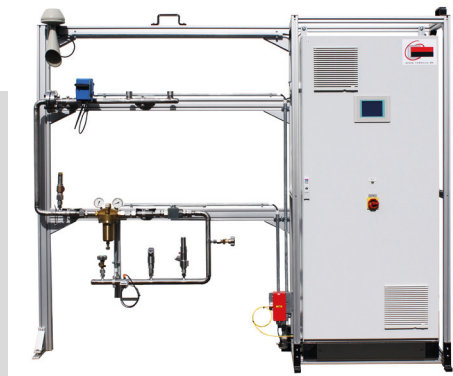

Application:

- Coal grinding systems
- Process Filter
- Storage Silos
- Dryers
- Other applications on request

The operating of a modern filter system without permanent control of dust emissions is currently not conceivable. This is relevant, not only in the view of the responsible authorities, but also the operators can see important advantages. robecco dust control determines in an effective way damages in filter separators. Optimisation of emission and filter monitoring guaranties high productivity.

General:

- Emission and filter monitoring in one device
- Avoidance of visible exhaust gas plumes
- Avoidance of product losses
- Simple erection and installation
- Simple maintenance of filter installations because of:
 - Early detection of ongoing bag filter damage
 - Location of damaged filter elements
 - Opportunity for specific maintenance actions

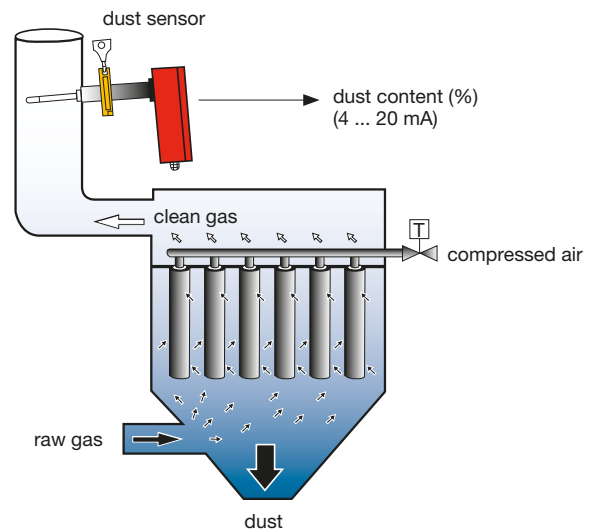

Filtercontroller RDC100C and RDC200 ATEX

Technical Dates:

- Case: Compact device (integrated operator unit), IP65
- Size: 80 x 175 x 65mm (W x H x D), Weight 2,0kg (RDC 100C)
- Size: 60 x 130 x 400mm (W x H x D), Weight 2,5 kg (RDC 200 ATEX)
- Sensor: Triboelectric Sensor with variable lengths (30 – 500mm), IP65
- Measuring range dust: 0... 100% / 0... 10 (1.000) mg/m³
- Calibration: by gravimetric reference measurements (for filter analysis not necessary)
- Monitoring: Graphic display with online diagram (RDC 200ATEX)
- Media temperature: max. 280°C (higher temperatures on request)
- Ambient temperature: -20... +50°C, dew point difference: min. +5K
- Flow velocity: from about 3m/s
- Analog output: 4... 20mA (galvanic amplifier on request)
- Digital signals: failure, two free adjustable limit values (0... 100 %) (RDC 100C)
- Digital signals: 3 potential free contacts (flow/maintenance, limit value 1 and 2) (RDC 200 ATEX)
- Power supply: 110V AC, 230V AC / 50 – 60Hz, 24V DC
- Power consumption: 5W
- ATEX – Conformity: Device Category 1/3D (RDC 200 ATEX)
- TÜV- approved: TA- Air
- Electro Magnetic Compatibility: conform to EMC- guideline 89/336/EWG and low voltage guideline 2006/95/EG

Application:

Emission and filter monitoring in

- Process filter
- Silo roof filter
- Dedusting systems



robecco silo automation controls in a reliable way silo plants to ensure a continuous operation for the production. Periphery equipment like filling stations, weighing units, conveyors, filters and extraction systems are integrated in the control concepts. robecco supports all projects with engineering, commissioning and training services. robecco silo automation RSA includes hardware and software for the complete silo control with adaption to upper PLC's. Software and hardware are optimized adapted on the process and will be adjusted during the commissioning phase.

Optionally integrated are following products:

- robecco G.A.S.
- robecco secure center RSC
- robecco inert control RIC
- robecco dust control RDC

General:

robecco silo automation monitors and controls the following processes and equipment:

- Analyser systems
- Temperature sensors
- Filling measurement
- Pressure sensors
- Exhaust filters
- Explosion vents
- Isolation equipment
- Filling stations
- Extraction systems
- Weighing units
- Quantity measuring units
- Inerting systems
- Earthing systems

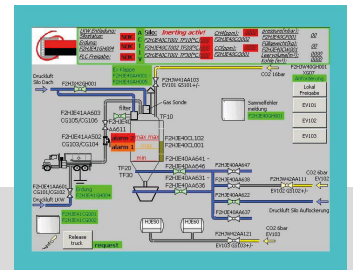

Services:

- Technical audits
- Planning and configuration
- Project management, Electrical and Mechanical
- Control solutions and programming
- Development, construction and installation of electrical components
- Commissioning service
- Switching cabinet manufacture
- Maintenance
- Spare part supply and After Sales Service

Application:

- Storage Silos for diverse materials
- Other applications on request

ROBECCO GENERATES

QUALITY · SAFETY · PRODUCTIVITY



rob ecco GmbH
Industriepark 17
56593 Horhausen
Germany
Fon: +49-2687-92626-0
Fax: +49-2687-92626-20
info@rob ecco.de
www.rob ecco.de